



filtration

HYDROFLUX
epco

WRC200 dNF40 Integrated Rack Design

**Technical
Datasheet**

Hollow fiber nanofiltration membrane module for water
and wastewater applications

WRC200 dNF40 Integrated Rack Design

Hollow fiber nanofiltration membrane module for water and wastewater applications

Product description

The WRC200 dNF40 Integrated Rack Design nanofiltration modules have the following features:

- Use for treatment of ground and surface water; reuse of industrial and municipal wastewater effluents;
- Excellent removal of color, turbidity, divalent ions and dissolved organics, including micropollutants;
- Inside-out operation in a cross-flow filtration mode, backwashable;
- Limited pretreatment required, no coagulation and no sludge production;
- Vertical mounting with rack connection capability;
- Excellent pH and chlorine tolerance;

Membrane specifications

Membrane material	Modified PES
MWCO ¹	400 Dalton
Min. MgSO ₄ rejection ²	91%
Membrane charge	Negative @ pH=7
Membrane fiber inner diameter	0.7 mm

¹ Molecular Weight Cut-Off (MWCO) is an estimation as it depends on size, shape, charge and polarity of the compound being tested, as well as test conditions.

² Test conditions: 5.0 mMol/L MgSO₄, 3.0 bar, 25°C, v=0.5 m/s.

Typical operating ranges

Max. system pressure ³	10 bar (145 psi)
Max. transmembrane pressure ³	6 bar (90 psi)
Max. backwash pressure ³	6 bar (90 psi)
Max. temperature during operation & cleaning	40°C (104°F)
pH range during operation	2-12
pH range during cleaning	1-13
Max. active chlorine concentration	500 ppm @ pH>10
Max. cumulative active chlorine exposure	250,000 ppm-hours @ pH>10
Cross-flow velocity range ⁴	0.1 – 1.0 m/s (2.25 – 22.5 m ³ /h per module) 0.33 – 3.3 ft/s (9.9 – 99 gpm per module)

³ Maximum pressures at 20°C.

⁴ Recommended velocity depends on feed water quality.

Feed water specifications

Max. TSS	300 ppm
Max. turbidity	150 NTU
Max. particle size	150 µm

WRC200 dNF40 Integrated Rack Design

Hollow fiber nanofiltration membrane module for water and wastewater applications

Module specifications

Membrane Surface Area 50 m² (538 ft²)

Module Dimensions

L1	1534 mm (60.39")	D1	200 mm (7.87")
L2	196 mm (7.71")	D2	168 mm (6.61")
L3	84 mm (3.30")	D3	2.0" Victaulic Style 75
L4	256 mm (10.07")	D4	219 mm (8.62")
L5	2046 mm (80.55")		
L6	1878 mm (73.94")		
L7	339 mm (13.35")		
L8	365 mm (14.37")		

Materials of construction

Housing PVC-U Cream

Internals PVC-U

Material Epoxy resin

Assembly components

1. Module
2. Feed/concentrate connection; Victaulic-CPVC-Reducing Coupling Style 358
3. Endcap; Victaulic-6" CPVC-Tee (No. 352)
4. Grooved coupling; Victaulic-CPVC-IR-Transition Coupling Style 357

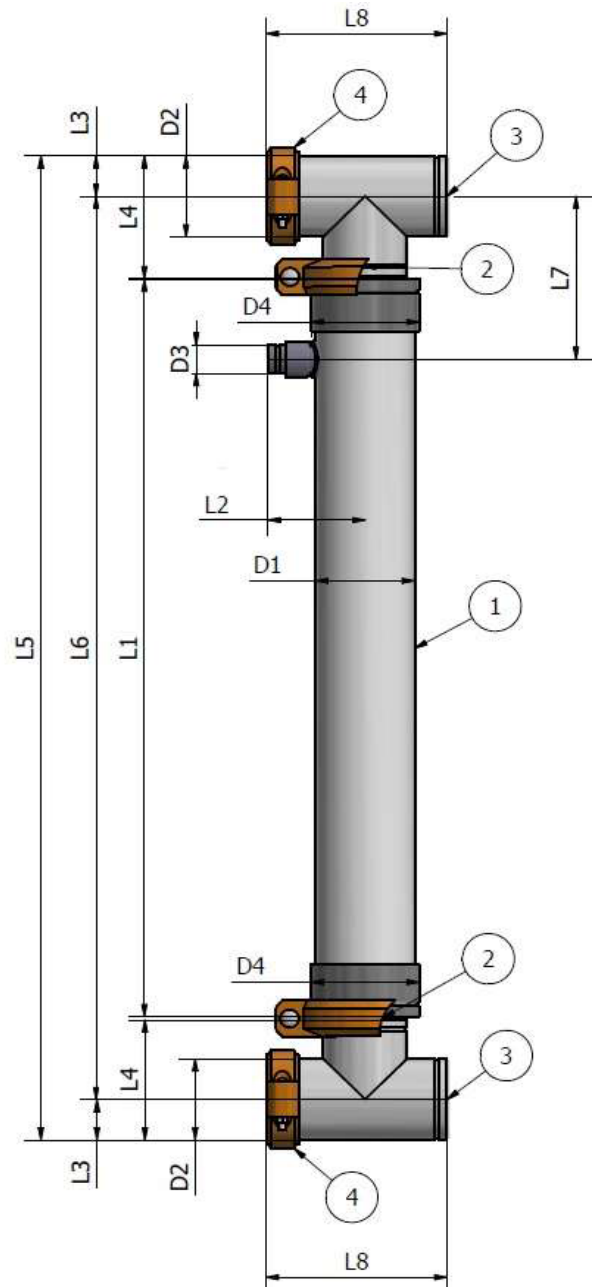

Product certifications



K100616

WRC200 dNF40 Integrated Rack Design

Hollow fiber nanofiltration membrane module for water and wastewater applications

Weight information

- Module (without accessories): 33.5 kg (74.5 lbs);
- Module with all accessories (2 endcaps + grooved couplings): 52 kg (115.5 lbs);
- Module full of water and all accessories: 88 kg (194 lbs);

Storage instructions

- New modules in original packaging can be stored for max. 1 year from shipping date in a dry place, protected from sunlight or any heat source, at temperatures between 0 and 40°C (32 and 104°F);
- Ex-factory storage solution: 79% water, 20% glycerin and 1% sodium bisulfite;

Shipping information

- Each module is individually packed in a vacuum sealed plastic bag;
- For small quantities, modules and endcaps are shipped in separate cardboard boxes;
- For large shipments, modules are loaded in a wooden crate with a max. of 20 modules per crate. Crate dimensions: 102 x 126 x 174 cm; 40 x 50 x 68 in (L x W x H)
- Shipping weight per module: 34.5 kg (76.5 lbs.);
- Shipping weight per endcap set: 18 kg (40 lbs.);
- Shipping weight per crate (20 modules), excl. endcap sets: 732.5 kg (1630 lbs.);

Release WRC200 dNF40 IRD -TDS 20210316

+61 2 9089 8833
info@hydrofluxepco.au
www.hydrofluxepco.au/

The statements, technical information and recommendations contained herein are believed to be accurate at the date of publication. Since the conditions and methods of use of the product and/or the information referred to herein are beyond our control, NX Filtration B.V. expressly disclaims any and all liability as to any results obtained from or arising out of any use of the product and/or reliance on such information. NO WARRANTIES OR GUARANTEES OF ANY KIND, EITHER EXPRESSED OR IMPLIED, INCLUDING BUT NOT LIMITED TO WARRANTIES OF MERCHANTABILITY, FITNESS FOR A PARTICULAR PURPOSE, OF TITLE, OF NONINFRINGEMENT OF THIRD-PARTY RIGHTS OR ANY OTHER WARRANTY ARE MADE CONCERNING THE PRODUCTS DESCRIBED AND/OR THE INFORMATION PROVIDED HEREIN.